

## LH3-UC25XS Horn loudspeaker,ex-proof,shrt flare IIB



The LH3-UC25XS horn loudspeaker is specifically designed and certified for installations where explosive gas-air mixtures are likely to be present. The horn is constructed from anti-static Polyamid material, making the horn sturdy and light weighted.

### Functions

The horn loudspeaker is standard supplied with a sturdy stainless steel mounting bracket allowing the sound beam to be accurately directed. The mounting bracket has a ratchet facility to ensure it stays correctly positioned. The connection cable is fed out through an ABS EX cable gland (M20) in the rear cover, which can be removed for entering the inside connection terminal

- ▶ IECEx/ATEX, US, CSA and CCC certified
- ▶ Constructed from sturdy, lightweight, anti-static Polyamid material
- ▶ Water- and dust-protected to class IP67
- ▶ Provision for connection of the optional supervision boards

block. For loop through connection, the rear cover is fitted with a second hole (covered with a blanking plug as standard supplied).

The horn loudspeaker includes a transformer for 100 V input voltage, with taps on the primary winding for different power settings.

The different power taps can easily be selected by connecting to the appropriate terminal of the 6-way terminal block.

For enabling loudspeaker supervision, a wire loop from the secondary side of the horn loudspeaker is available in the connection area. This wire loop is normally closed, but if used with the supervision board, cut and connected.

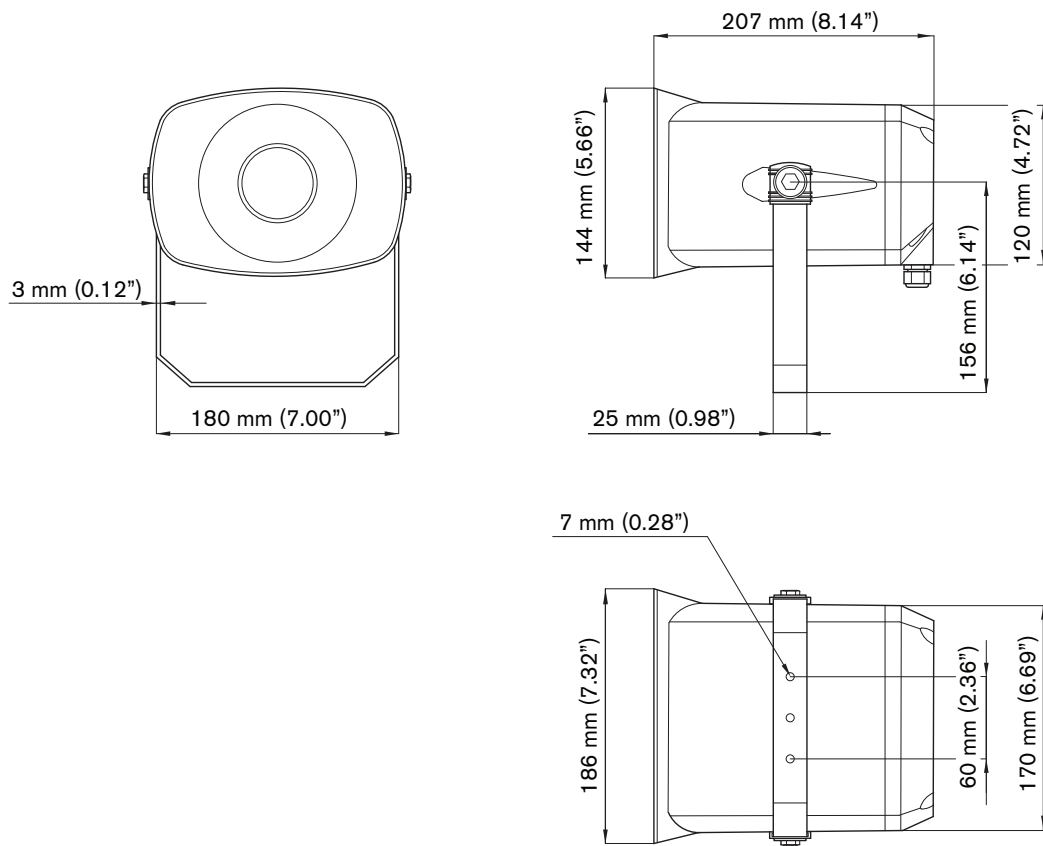

Fig. 1: Dimensions in mm (inch)

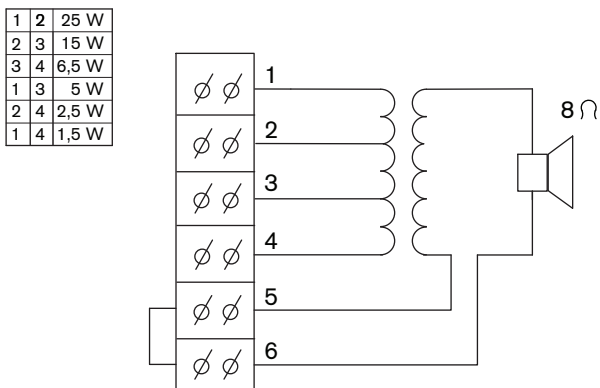

Fig. 2: Circuit diagram

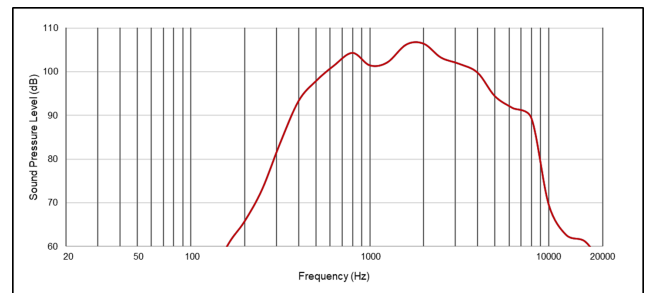

Fig. 3: Frequency response

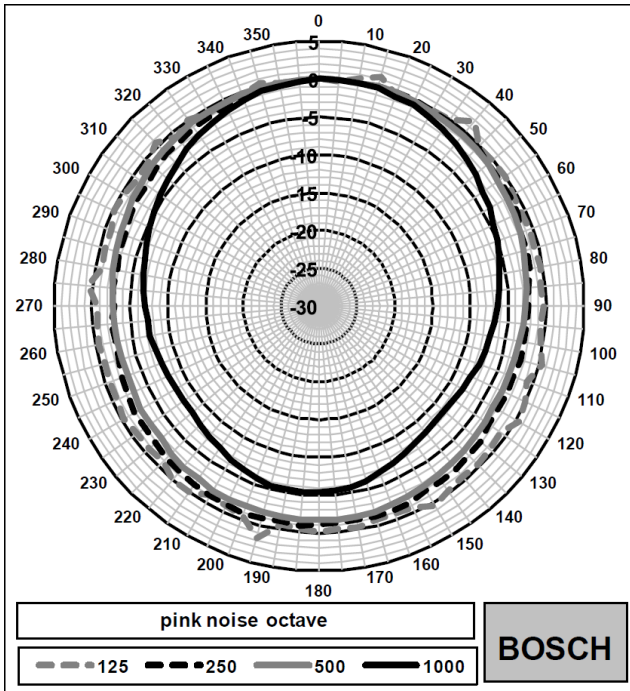

Fig. 4: Horizontal polar diagram (low frequency part)

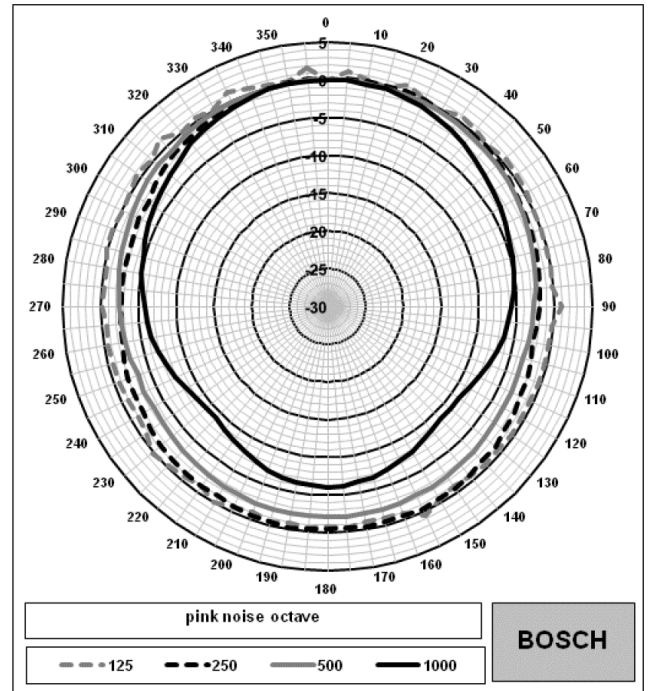

Fig. 6: Vertical polar diagram (low frequency part)

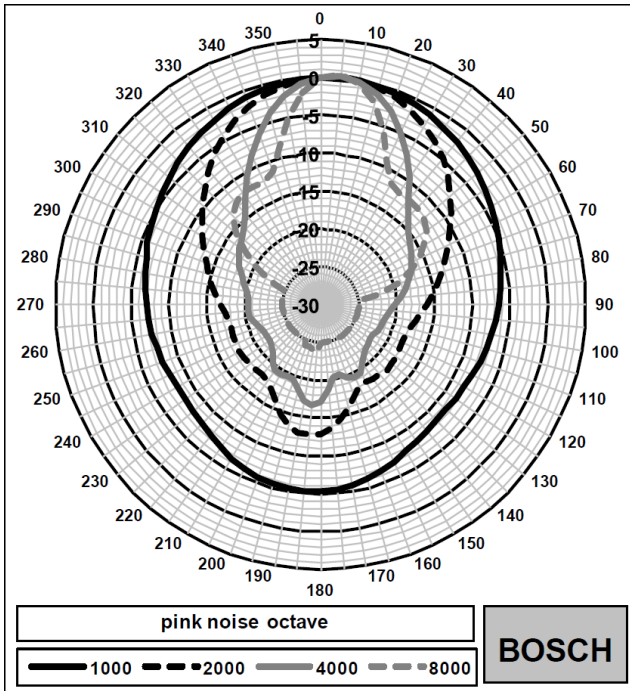

Fig. 5: Horizontal polar diagram (high frequency part)

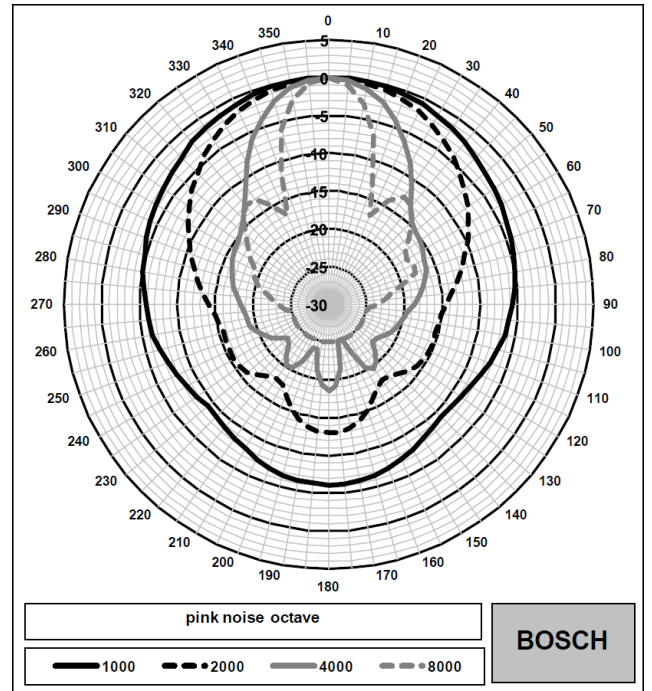

Fig. 7: Vertical polar diagram (high frequency part)

Octave band sensitivity*			
	Octave SPL 1W/1m	Total octave SPL 1W/1m	Total octave SPL Pmax/1m
125 Hz	57.9	-	-
250 Hz	81.3	-	-
500 Hz	97.6	-	-
1000 Hz	103.8	-	-
2000 Hz	105.7		
4000 Hz	99.8	-	-
8000 Hz	97.0	-	-
A-weighted	-	99.7	111.7
Lin-weighted	-	99.1	111.3

Octave band opening angles			
	Horizontal	Vertical	
125 Hz	360	360	
250 Hz	360	360	
500 Hz	360	360	
1000 Hz	155	188	
2000 Hz	81	95	
4000 Hz	47	50	
8000 Hz	32	29	

Acoustical performance specified per octave \* (all measurements are done with a pink noise signal; the values are in dB SPL).

### Regulatory information

#### Quality assurance

All Bosch loudspeakers are designed to withstand operating at their rated power for 100 hours in accordance with IEC 60268-5 Power Handling Capacity (PHC) standards. Bosch has also developed the Simulated Acoustical Feedback Exposure (SAFE) test to demonstrate that they can withstand two times their rated power for short durations. This ensures improved reliability under extreme

conditions, leading to higher customer satisfaction, longer operating life, and lessens the chance of failure or performance deterioration.

Safety	According to EN 62368-1
Water and dust	According to EN 60529, IP 66/67
IECEX / ATEX	IECEX DNV 21.0015X & Presafe 20 ATEX 05429X II 2G Ex db eb mb IIB+H2 T4 Gb II 2D Ex tb IIIC T105 °C Db
CSA	Ex db eb mb IIB + H2 T4 Gb LC19,17779 (Canada) Ex tb IIIC T105°C Db IP66/67
US	Class 1 Zone 1 AEx db eb mb IIB + H2 T4 LC19A17779 Gb (US) Zone 21 AEx tb mb IIIC T105°C Db IP66/67
CCC	Ex db eb mb IIB+H2 T4 Gb Ex db eb mb IIC T4 Gb Ex tb IIC T105° Db

### Parts included

Quantity	Component
1	LH3-UC25XS Horn Loudspeaker
1	Installation instruction
1	M20 Ex Cable gland PG13

### Technical specifications

#### Electrical\*

Rated power (PHC)	25 W
Rated power	25 / 15 / 6.5 / 5 / 2.5 / 1.5 W
Sound pressure level at rated power / 1 W (1 kHz, 1 m)	118 dB / 106 dB
Opening angle at 1 kHz/ 4 kHz (- 6 dB)	120 / 37 degrees
Effective frequency range (-10 dB)	380 Hz to 8000 Hz
Rated voltage	100 V
Rated impedance	400 ohm
Electrical connection	2 x 6 pole push terminal

Acceptable wire gauge	0.5 mm - 2.5 mm <sup>2</sup> (AWG 20-12)
-----------------------	--

\* *Technical performance data acc. to IEC 60268-5*

### Mechanical

Material horn	Polyamide (PA)
Material bracket	Stainless Steel (Grade 316)
Dimensions (H x W x D)	144 x 170 x 207 mm (5.66 x 6.69 x 8.15 in)
Weight	2.37 kg (5.22 lb)
Color	Black (RAL 9005)
Cable gland (standard supplied)	M20 Polyamide (PA)
Cable diameter	11 mm to 14 mm (0.43 in to 0.55 in)

### Environmental

Operating temperature	-50 °C to +60 °C (-58 °F to +140 °F)
Storage temperature	-40 °C to +70 °C (-40 °F to +158 °F)
Relative humidity	<95%

### Ordering information

#### **LH3-UC25XS Horn loudspeaker,ex-proof,shrt flare IIB**

Flameproof horn loudspeaker with short flare.

Order number **LH3-UC25XS | F.01U.318.943**

### Services

#### **EWE-HRNEXF-IW 12 mths wrty ext horn flameproof**

12 months warranty extension

Order number **EWE-HRNEXF-IW | F.01U.360.714**



<https://www.boschsecurity.com>